



Your service partner



**LAE Anlagenbau GmbH**  
 Altenwalder Chaussee 94-100  
 D – 27472 Cuxhaven  
 GERMANY  
 Tel.: +49 4721 105 0  
 FAX : +49 4721 105 210  
 Mail : [info@lae-cuxhaven.de](mailto:info@lae-cuxhaven.de)  
 Web : <https://lae-cuxhaven.de>

# Munters »REV-AL« / »REV-AL«light

## Heating systems

»REV-AL« / »REV-AL«light finned tubes ensure comfortable warmth in the stable without creating their own air circulation. Due to the larger surface in comparison with the other tubes, the heating capacity is significantly improved and due to the fin arrangement, the flow between the spaces is optimal (e.g. with jet ventilation).

### Features

- Up to 30% performance increase
- Up to 85% weight reduction (when comparing steel with aluminium)
- 100% easy installation by means of connection clamps
- High radiated power due to epoxy-coated surface
- Energy-saving, made of aluminium with high heat conduction
- Higher resistance against ammonia
- Optimised surface more watts per running metre (Btu per feet)

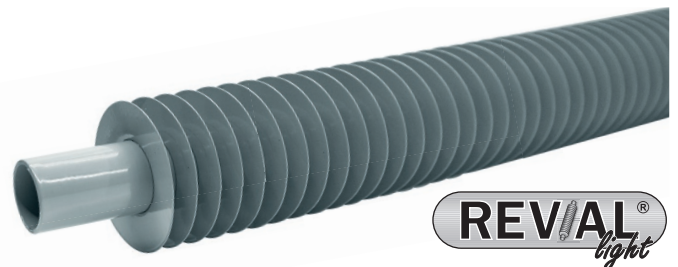

These systems are the ideal choice in particular for the preheating or for use in conjunction with diffusing fresh air systems. The »REV-AL« / »REV-AL«light finned tubes can be installed in the immediate vicinity of the fresh air system for the heating of the incoming fresh air. A max. heat emission is achieved due to the large surfaces of the »finned tubes«. The pipes are manufactured of epoxy-coated aluminium and in addition to the lower weight, they are an ideal heat conductor. The smooth and epoxy-coated surface enables the easy cleaning of the »aluminium finned tubes« and are considerably more resistant against ammonia.

Dimensions and connections can be found on the back of the page.

### »Details + Hanging variants«



Retainer hook for finned tubes



Coupling elbow 90°



Exhausters



Wall bracket

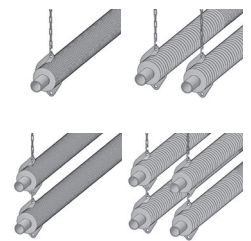

Hanging variants

# Munters »REV-AL« / »REV-AL«light

## Heating systems

### Overview

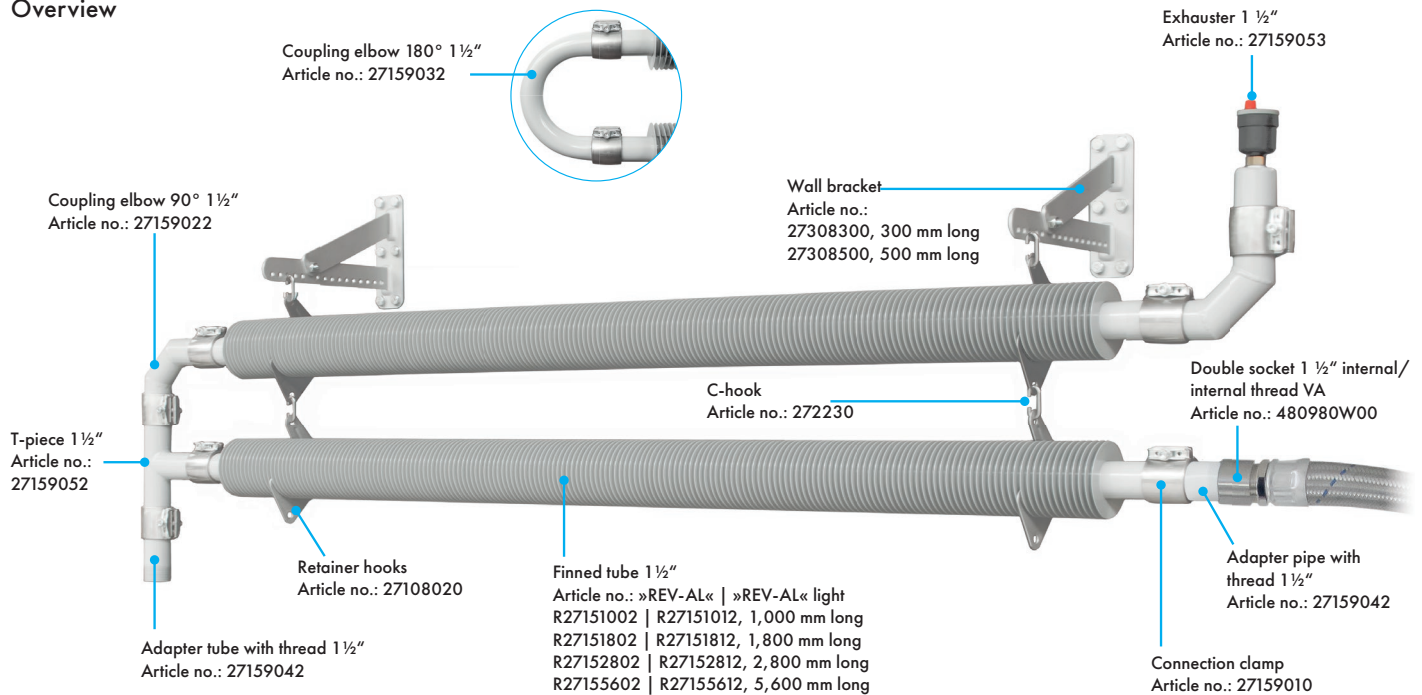

The finned tubes are available with a length of 1,000 / 1,800 / 2,800 and 5,000 mm (39,3 / 70,9 / 110,2 and 220,5 inch) and are therefore suitable for various applications. The connection is performed with standard 1.5" fittings. The individual pipes can be easily installed with connection clamps

Heating pipes are often exposed to a high concentrations of ammonia in stables. The resistance against gaseous ammonia can differ greatly in different materials.

The test confirms that the »REV-AL« / »REV-AL«light finned tubes are resistant against the effects of the stable air for a service life of at least 20 years.

	Steel	»REV-AL«	»REV-AL« light
Heating capacity	100%	130%	100%
Weight	100%	-80%	-85%
Easy to assemble	—	✓	✓
Cleaning	👎	👎	👍



Control unit 180 kW

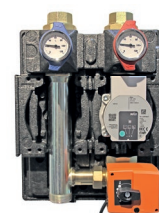

Control unit 20–60 kW

### Heat emission

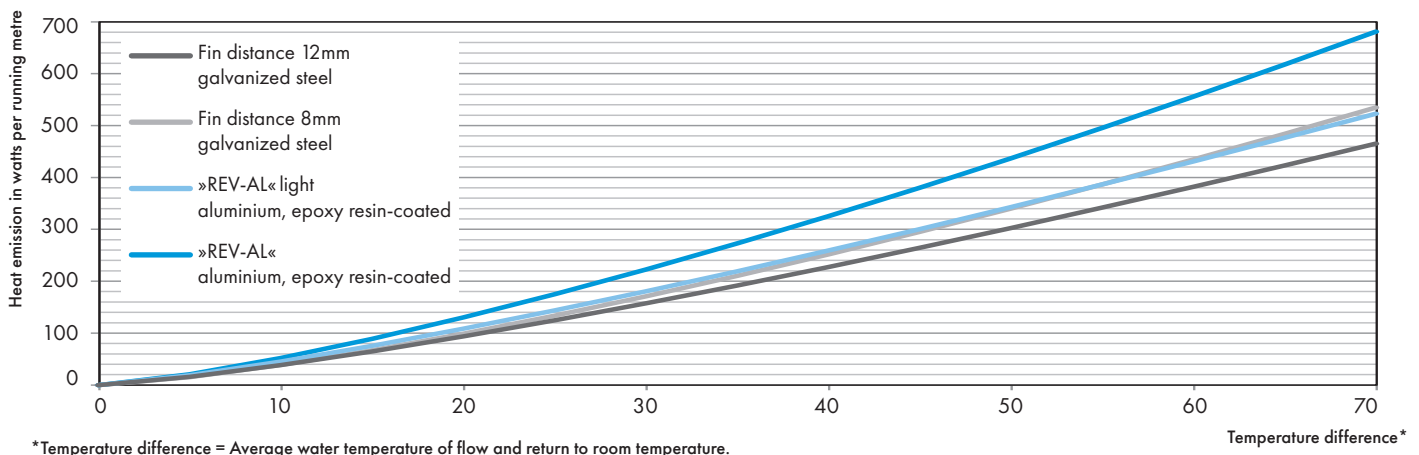

Find your nearest Munters office at [www.munters.com](http://www.munters.com)

Munters reserves the right to make alterations to specifications, quantities, etc., for production or other reasons, subsequent to publication. © Munters AB, 2021