

Program overview

- Main light
- Night light
- System light
- Water
- Feed
- Animate

Production Last 14 days

855 kg	1,020 kg	1,195 kg
-7 days	Now	

▲ 175 kg | 1,195 kg >

▼ 1,020 kg | 2,031 l >

▲ 4 g | 1,518 g >

Eggs 14736 > | Mortality 0.2% ▼ 0.1% >

Environmental Data:

- Temperature: 21.0 °C (Feel like 21.0 °C)
- Humidity: 67%
- CO₂: 560 ppm
- Ventilation: 63.1%

Climate and Farm Management Layers

Your service partner



LAE Anlagenbau GmbH
 Altenwalder Chaussee 94-100
 D – 27472 Cuxhaven
 GERMANY
 Tel.: +49 4721 105 0
 FAX : +49 4721 105 210
 Mail : info@lae-cuxhaven.de
 Web : <https://lae-cuxhaven.de>



www.skov.com

SKOV

Climate for growth since 1966



Leo Østergaard, CEO, SKOV A/S



Østergaard, where it all started.

SKOV contributes to efficient and sustainable global food production that delivers healthy food produced in respect to animal welfare.

We provide climate solutions, farm management, and digital value chain services for animal production worldwide.

When partnering with SKOV, we are with you from the design phase to the final project. You will have a partner who can translate knowledge into solutions that will increase your livestock production and profit.

"We work for optimum conditions for animals, people, and the environment. Our systems can be adapted to all types of buildings and are reliable and efficient under all climatic conditions."

– Leo Østergaard, CEO, SKOV A/S

SKOV

Worldwide presence



SKOV Headquarter, R&D, Test Center & Production. Glyngøre.

It is essential to know the conditions under which the system is installed to fulfill customer requirements and their needs for a well-functioning system.

It requires a thorough knowledge of the local conditions, including climate, legislation, building styles, etc.; at the same time, it is also advantageous to be close to the project.

Furthermore, the customer should have access to advice from SKOV, and be able to enter into discussions, at all times, which is why we have built an extensive network of distributors and service partners to cover all time zones.

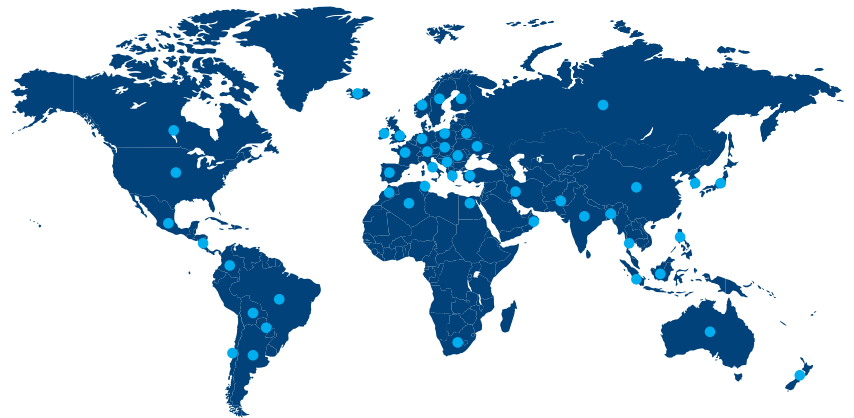

Why SKOV

Company DNA



Future-proof products

Our products are developed and refined in collaboration with farmers worldwide to meet your exact needs in your production.

Big data – great value

Our data-driven solutions enable you to follow and adjust the conditions in your livestock house in real time.

Tested to last

Our products go through significant test processes before being launched to the market. We measure product performance on a 1:1 scale at our air physics test center.

Made in Denmark

We produce all SKOV controllers in Glyngøre, Denmark, in an efficient, modern, ISO-certified electronics production that ensures high-quality products.

Customized solution

Our projecting department transforms your ideas and wishes into system solutions in close collaboration with you and other relevant partners.

On-time delivery

We emphasize the importance of timely and correct delivery. Our logistics center ensures delivery of all domestic and worldwide shipments on schedule.

Financial support

Our finance department can help you realize your project with the best financial terms.

One point of contact

Your SKOV Project Manager follows up on schedules and deliveries and ensures that the goods are delivered on time.

Make it work

The installation is in safe hands when our technical fitters are in charge. We can also offer to supervise the installation if you and your staff prefer to do the installation yourselves.

Help to get started

We are with you all the way and make sure that you and your staff are briefed and instructed on the best use of the ventilation system.

SKOV Academy – Let's go training

We conduct training sessions at our headquarters in Denmark and on farms all year round, worldwide.

Service 24/7/365

You can expect to have a speedy and expert service when needed. Either by SKOV service personnel or through our many distributors and their staff.

Continuous operation

We are with you all the way and ensure that you and your staff are briefed and instructed on the best use of the ventilation system. Regular service ensures that your production runs optimally with no downtime.

Introduction to ventilation

Climate for Growth



The housing climate is one of the most critical factors for animal welfare

It places heavy demands on the ventilation system to ensure the correct temperature, air quality, and humidity regardless of the outside climate conditions.

An optimum climate ensures an optimum comfort zone – a temperature range where the animals feel neither hot nor cold.

If the temperature is too low, the animals use feed to maintain their body temperature instead of producing eggs.

Too high a temperature reduces the feed intake, so the animals drink more water. The layers do not get enough energy and minerals to produce large eggs with good shells. They will still try to lay an egg daily, but the eggs are getting smaller, and the shells are of poorer quality and break easily.

Correct and efficient ventilation contributes to the following:

- Large eggs with good shell
- Higher returns per square meter
- Reduced use of veterinary medicines
- Fewer diseases and higher animal welfare
- Lower mortality rate
- Lower energy consumption

Low Power Ventilation (LPV) System

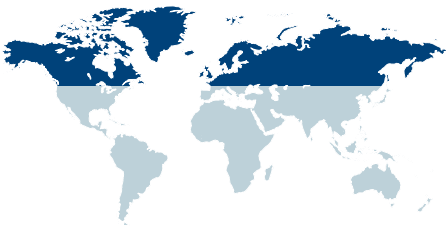

Correct control of air direction, volume, and velocity

The LPV system is a classic negative pressure system used for the ventilation of poultry production facilities. The system is intended for temperate regions of the world and can be adapted to most livestock houses.

During cold periods, fresh air is mixed with the housing air before reaching the area occupied by the birds. During warm periods, the air is sucked into the livestock house at a higher speed resulting in air circulation around the birds.

Benefits:

- Uniform climate all year round for the birds
- Low energy and heating consumption
- Low running costs, efficient chimneys, fans, and control principles
- Emergency opening system for maximum security
- Easy to install and low maintenance costs

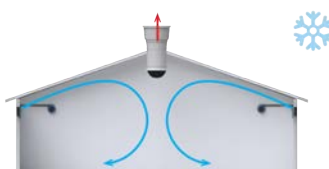
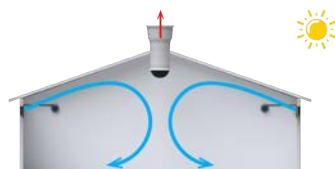

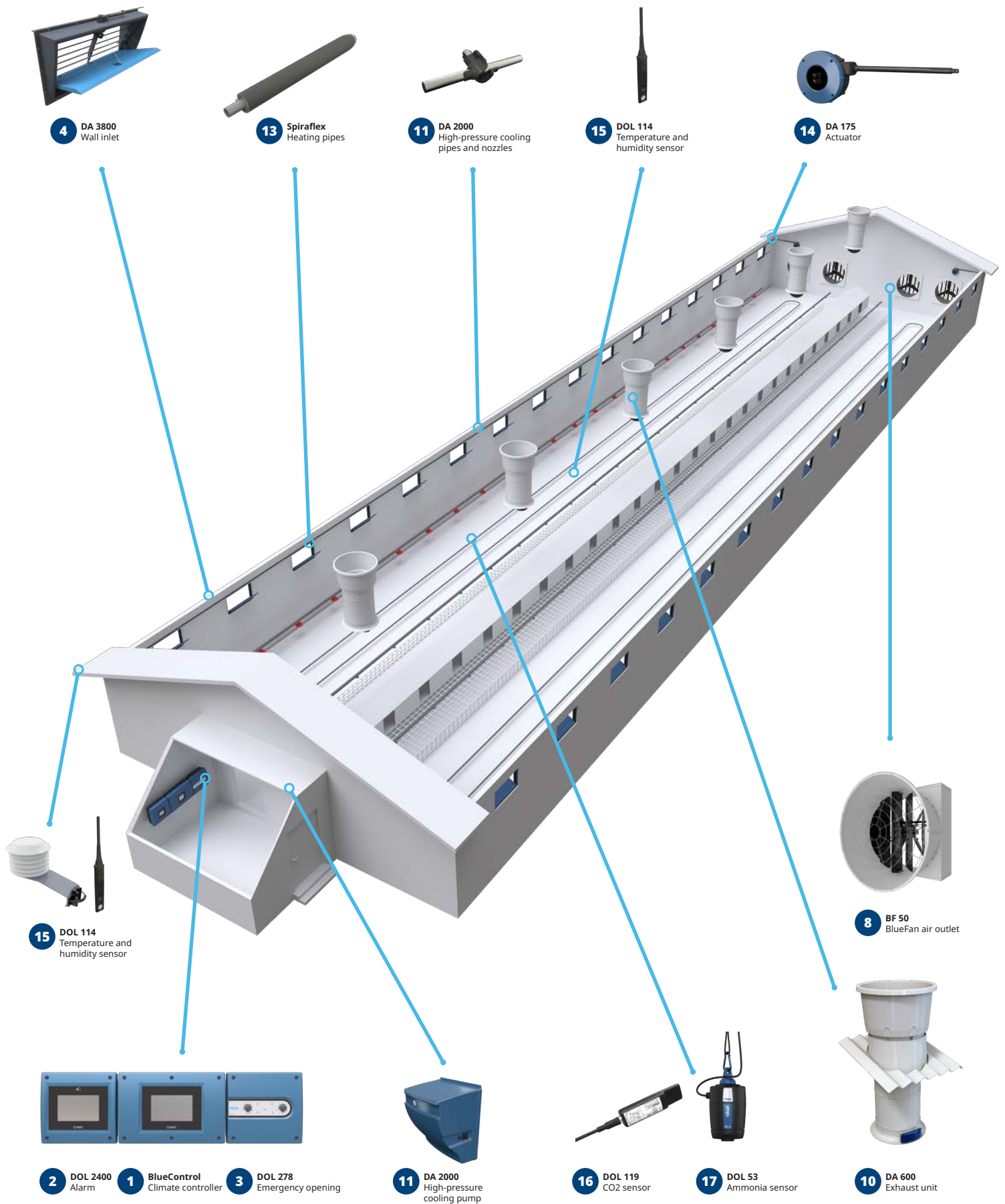

4 DA 3800 Wall inlet

13 Spiraflex Heating pipes

11 DA 2000 High-pressure cooling pipes and nozzles

15 DOL 114 Temperature and humidity sensor

14 DA 175 Actuator

15 DOL 114 Temperature and humidity sensor

8 BF 50 BlueFan air outlet

2 DOL 2400 Alarm

1 BlueControl Climate controller

3 DOL 278 Emergency opening

11 DA 2000 High-pressure cooling pump

16 DOL 119 CO2 sensor

17 DOL 53 Ammonia sensor

10 DA 600 Exhaust unit

Combi-Tunnel (CT) System



The best productivity conditions in a changing climate

Combi-Tunnel is a fully automatic, all-weather system that provides the best productivity conditions when the outside temperature changes from very cold to very hot.

When the outside temperature is low the system is working in side mode. It keeps the temperature and air humidity at an ideal level by removing excess humidity and heat generated inside the house. When the outside temperature is high, the system is working in tunnel mode and cools the animals via air velocity and cooling systems.

Benefits:

- Automatic adaption to the outside temperature and age of the birds
- Closed production environment
- Controlling temperature, humidity, air velocity, and air quality
- Same climate all over the house during cold periods
- Using air velocity as a chill effect during hot periods
- Uniform distribution of the animals

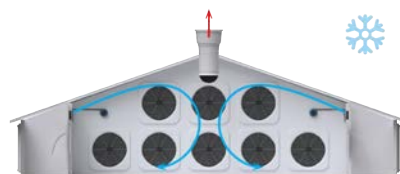
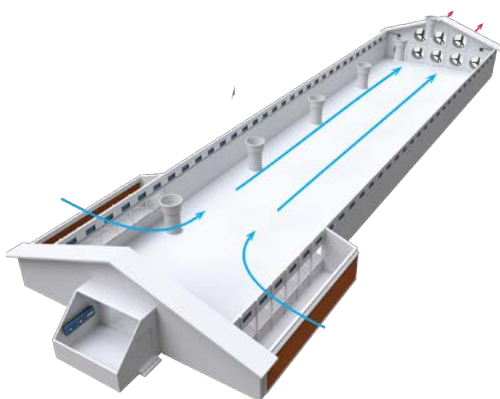

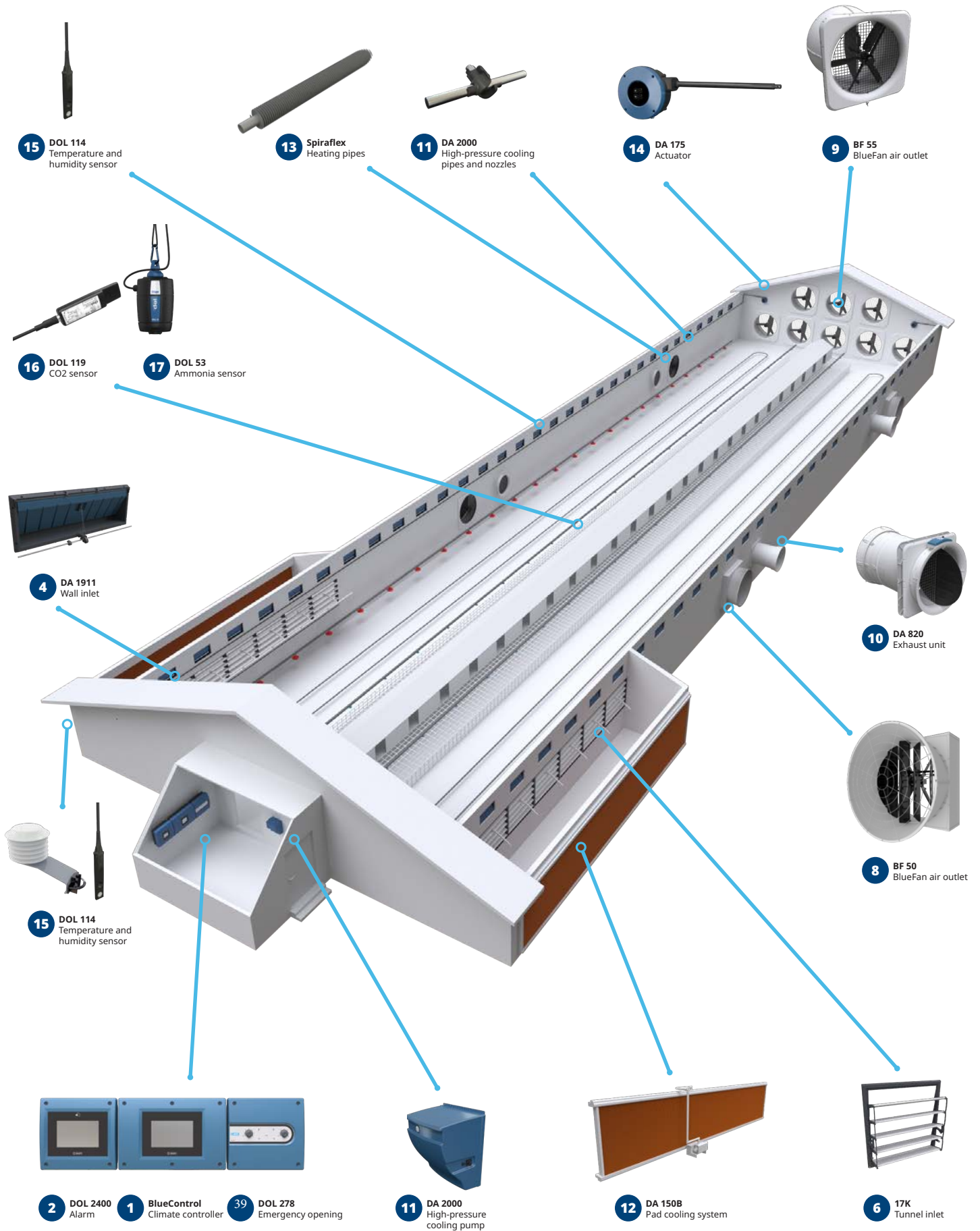

15 DOL 114
Temperature and
humidity sensor

13 Spiraflex
Heating pipes

11 DA 2000
High-pressure cooling
pipes and nozzles

14 DA 175
Actuator

9 BF 55
BlueFan air outlet

16 DOL 119
CO2 sensor

17 DOL 53
Ammonia sensor

4 DA 1911
Wall inlet

10 DA 820
Exhaust unit

15 DOL 114
Temperature and
humidity sensor

8 BF 50
BlueFan air outlet

2 DOL 2400
Alarm

1 BlueControl
Climate controller

39 DOL 278
Emergency opening

11 DA 2000
High-pressure
cooling pump

12 DA 150B
Pad cooling system

6 17K
Tunnel inlet

Tunnel System

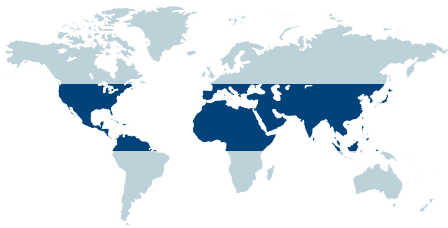

A simple system that cools the birds

With SKOV's Tunnel ventilation, you ensure the correct temperature in the livestock house, despite the high outside temperatures.

In a Tunnel ventilation system, the air intake is placed in the sides or at one end of the building. The air intake is lined with cooling pads. At the opposite end of the tunnel opening, large gable fans create a cooling air current (chill effect) along the longitudinal direction of the livestock house.

Benefits:

- Low initial costs
- Perfect system for tropical regions due to high air velocity with chill effect and cooling control
- A cost-effective way to cool down birds in a tropical climate
- Advanced cooling control providing a stable climate
- The system efficiently removes excess heat and undesirable gases

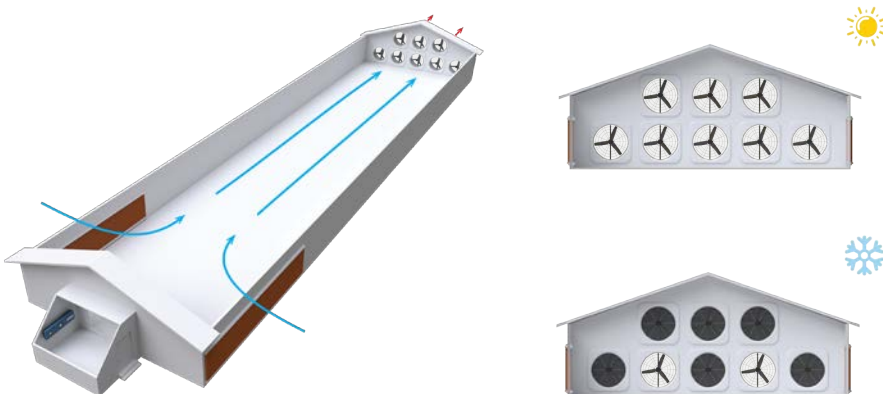

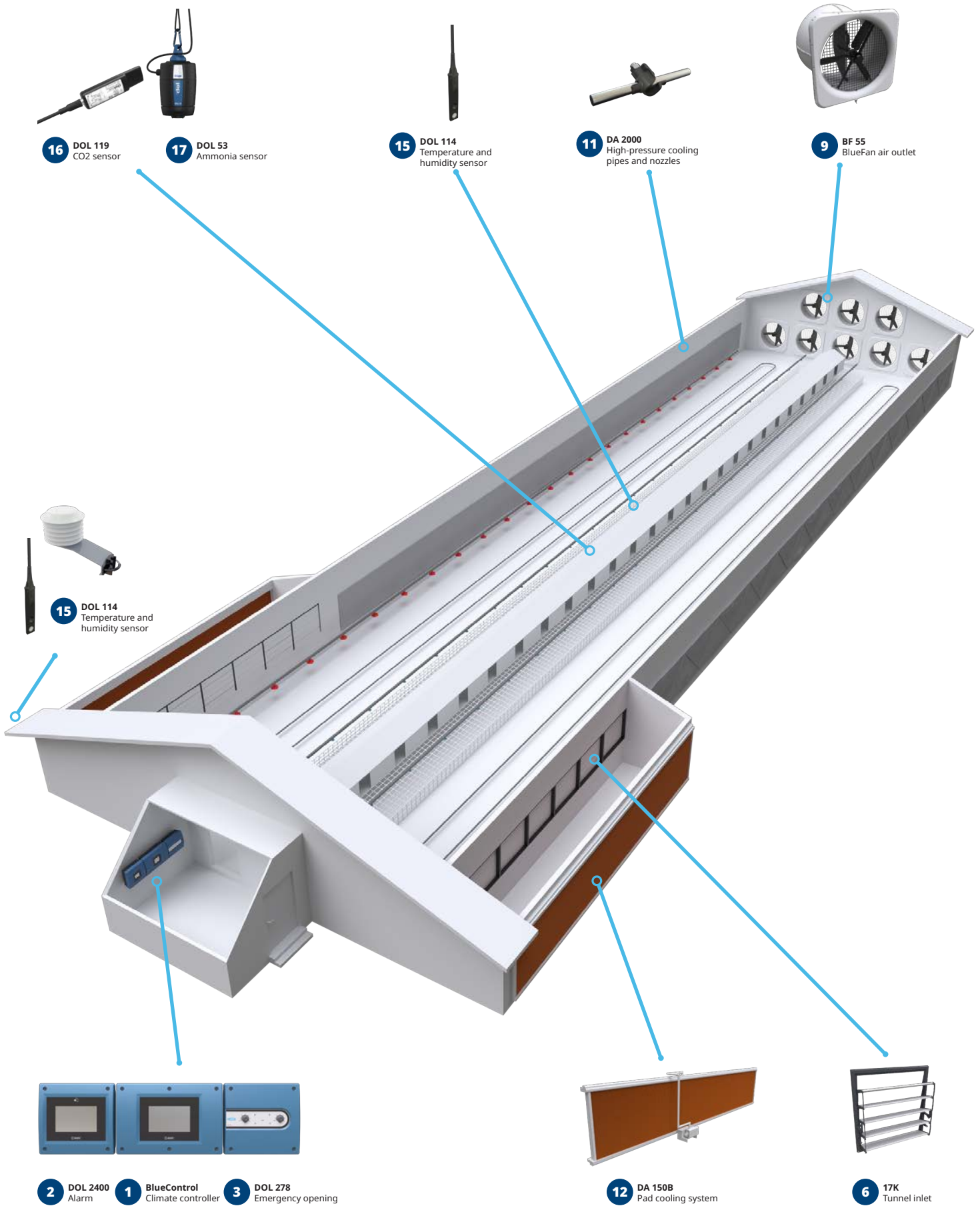

Equal pressure System

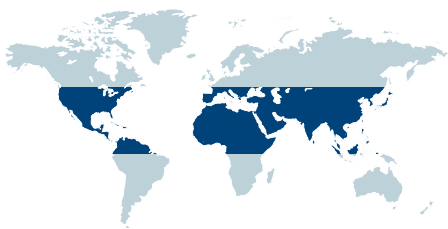

Full control of air intake and air outlet

The equal-pressure system is intended for temperate regions of the world and can be adapted to most poultry houses.

In an equal-pressure system, the fresh air is supplied through the roof inlets, and the air outlet is conducted through the exhaust units equipped with active fans, ensuring a neutral pressure. Especially poultry houses with freerange facilities require equal-pressure ventilation.

Advantages:

- Large eggs with good shell
- Higher returns per square meter
- Reduced use of veterinary medicines
- Fewer diseases and higher animal welfare
- Lower mortality rate
- Lower energy consumption

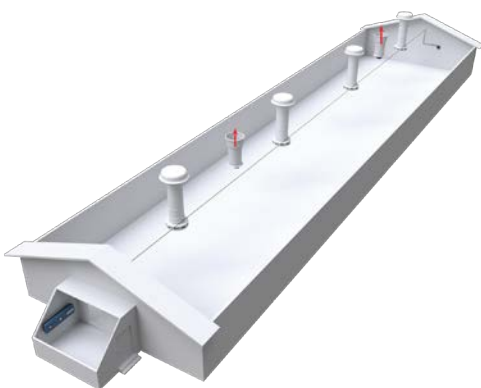

The roof unit DA 60-820 can also be used as an air inlet without a fan. The system then works as a classic negative pressure system. It is not possible to use the system in connection with free-range production.

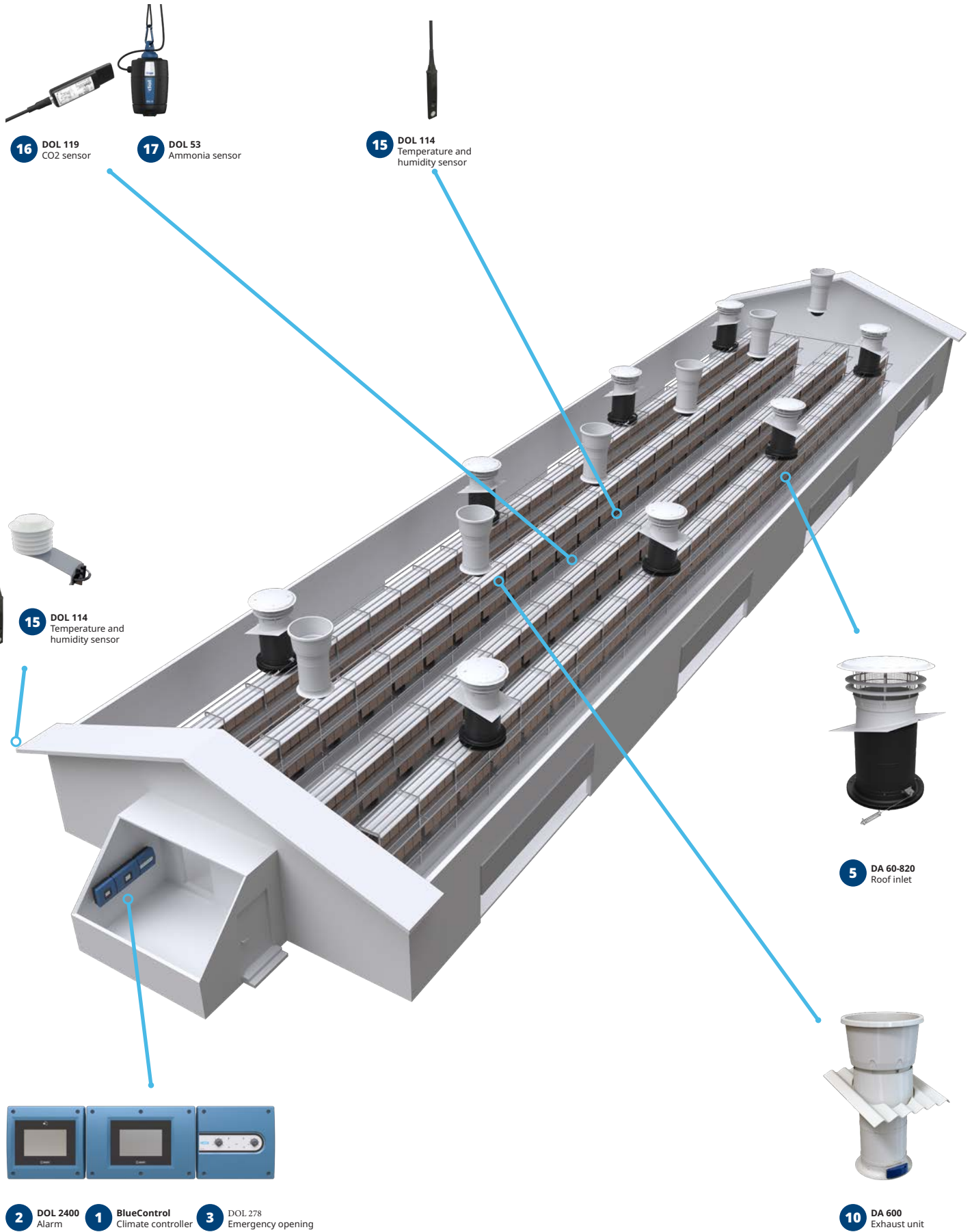

Layer Production

Breeder

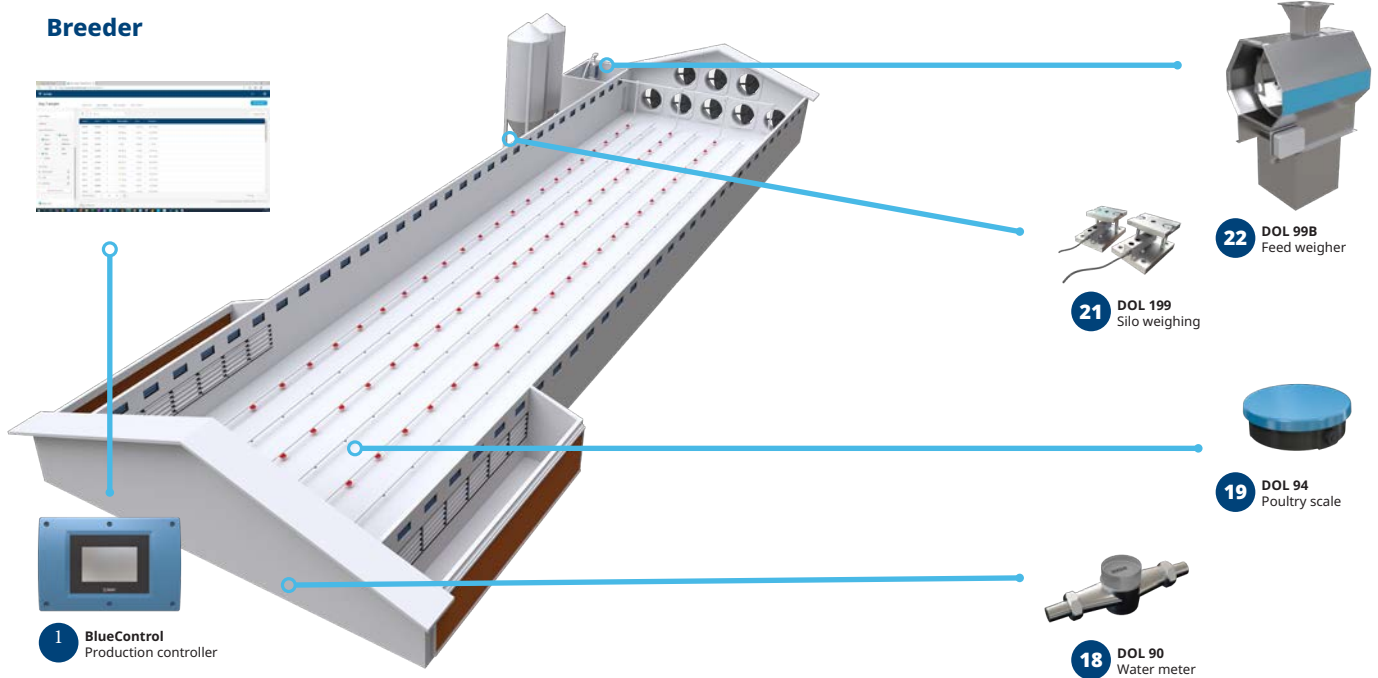

Layer

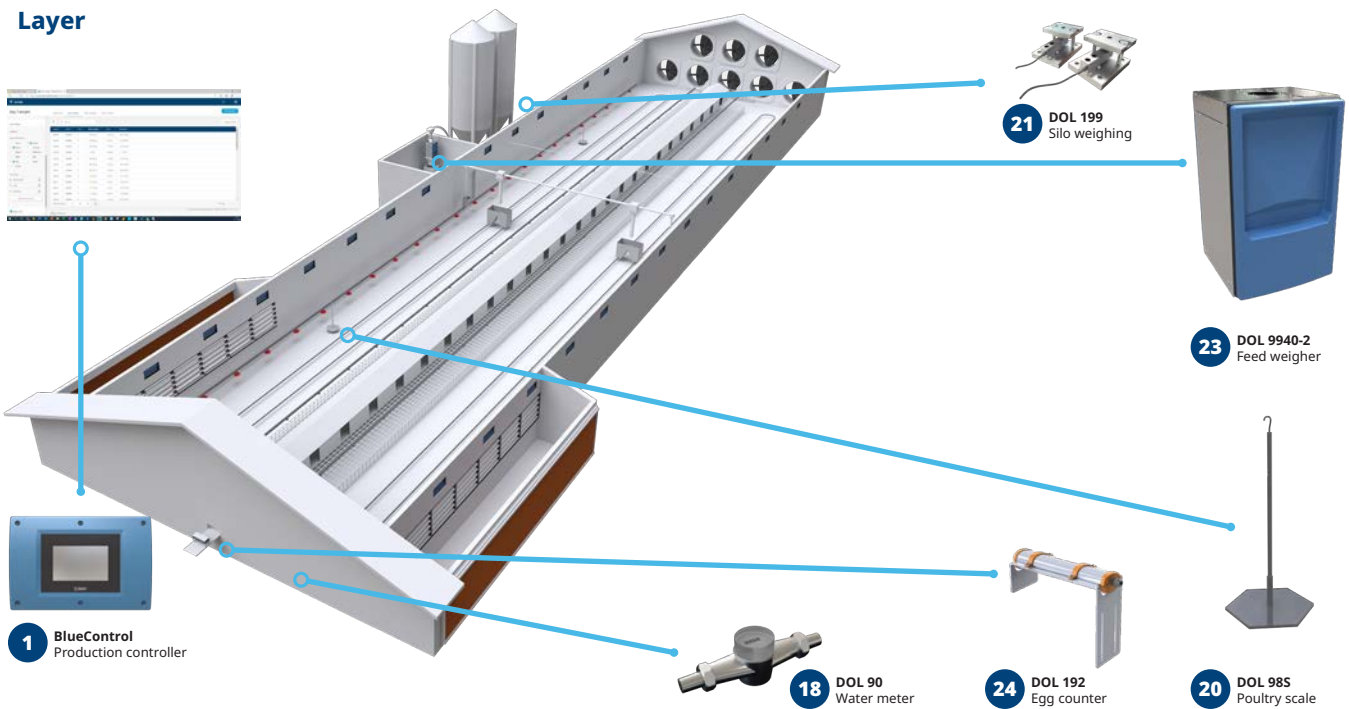

Production

Control of feed, water, weight, and light



Providing the best results requires being able to monitor production continuously and make corrections if it takes an unexpected turn. SKOV's production controller includes production modules adapted to rearing and layer facilities. The functions enable systematic monitoring and effective control of production.

Rearing

In rearing facilities, it is important to monitor growth and uniformity and ensure the correct amount of feed that supports the weight of the animals. Light control is an important parameter in rearing productions. The light program encourages growth during rearing and controls the birds' sexual maturity.

Based on the weighing data, the producer can monitor whether the production progresses as desired or whether the lighting, water, or feed program needs adjustment. The weight of the animals is also an indicator of whether other conditions in the house need adjustment.

Advantages:

- Uniform growth through feed and lighting programs
- Lighting program that matches the needs during the animals' growth period
- Water monitoring and control - quick response in the event of irregularities

Layer

Obtaining the best results requires monitoring the production continuously and making corrections if it takes an unexpected turn. In egg production, it is crucial to monitor the production, control the feed distribution, and monitor the feed intake and weight of the animals. One or more electronic egg counters automatically count the number of produced eggs. It is also possible to record floor eggs, system egg eggs, and nest eggs.

Light in different zones and flexible light programs help improve production and ensure birds are in the right place to rest.

Advantages:

- Continuous monitoring and production control
- Advanced feed program for the entire batch
- Advanced feed program ensuring an optimum egg production
- Water monitoring and control - quick response in the event of irregularities

Farm Management

Increase your productivity



A SKOV controller controls the climate and production at house level and transfers the data to FarmOnline.

All essential climate and production data is displayed on one screen in FarmOnline – providing a quick overview and enabling in-depth analyses. The program allows you to view and change selected key values for temperature, humidity, ventilation, cooling, and heating.

It gives you an easy overview of current and historical data, making it possible to monitor the development of individual batches and compare between houses, as well as historical batches.

Business perspective

Companies that own several farms in several locations can access data to get a complete overview of their farms, enabling them to develop their businesses further.

Data is transferred directly from the controller to the management system PC at headquarters. Data is in real time and not influenced by any manual processes that can cause errors and lower the data validity.

It enables management to compare essential production data across the individual farms and concentrate the efforts on farms where productivity needs improvement.

Benefits:

- Trustworthy, validated, and filtered data from an unlimited number of farms
- A complete overview of production at all levels – farms, regions, and worldwide
- Possibility to initiate quick action in case of irregularities on any farm regardless of location
- Improved production and business development based on reliable real-time data
- Efficient implementation of management strategies in the various regions

Farm Mangement

FarmOnline Apps

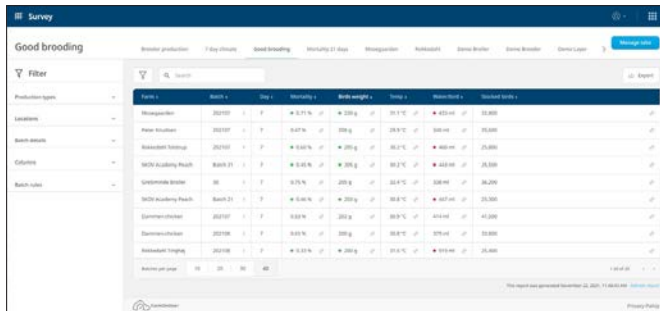

Survey

The survey module provides a comprehensive overview of climate and production data for an unlimited number of farms and houses. The overview displays real-time data without any delay.

Benefits:

- Many houses - compiled overview
- Use the skilled labor optimally
- Use good experiences from one farm on other farms

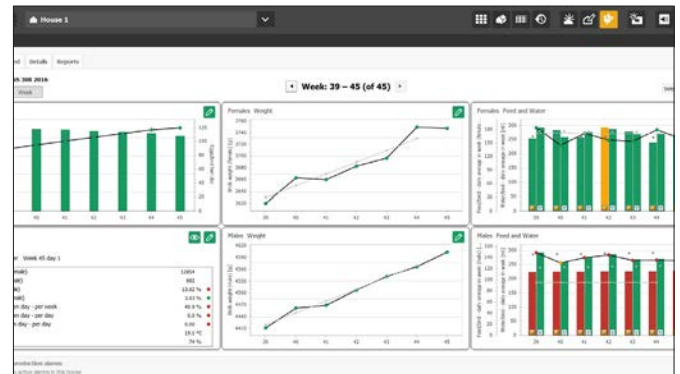

Production - Layer

The layer production module contributes relevant analyses based on feed, light, water, eggs, and mortality information.

Benefits:

- Optimizes the ratio of growth and produced eggs
- Quick overview - spend time on the animals, not in the office
- Observe deviations before they have implications

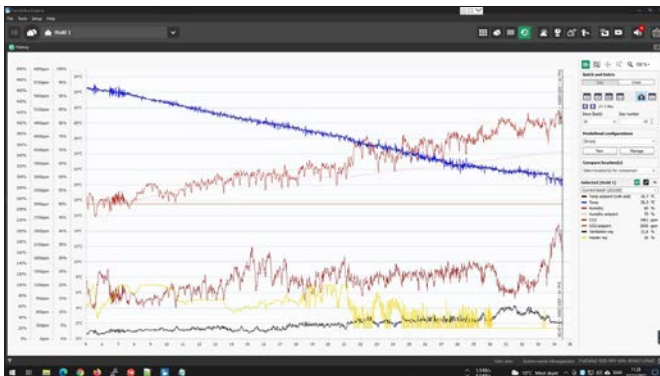

Climate

The module typically shows the climate data for temperature and humidity but can also display data for CO2 and ammonia.

Benefits:

- Stable livestock house climate - uniformly high productivity
- Quick overview - spend time on the animals, not in the office
- Observe deviations before they have consequences

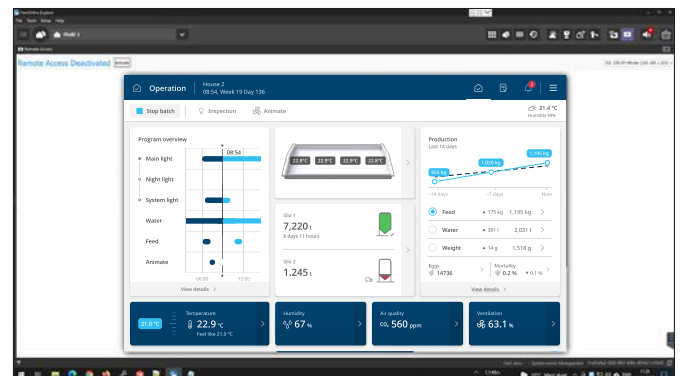

Remote Access

The Remote Access module provides the option to obtain a 100% identical display and operation of all climate and production controllers connected to the network.

Benefits:

- Same operation by you - in the house or the office
- Safety in operation - avoid errors
- Service technician or adviser guides you remotely

System Components



1

BlueControl climate and production controller

- Precise and efficient control of the climate and production in the poultry house
- Flexible solution of software and hardware
- Climate regulation is based on temperature and humidity, but also the CO₂ and NH₃ level
- Precise climate control – optimal growth condition for all poultry in the house
- Adaptive Control – artificial intelligence to secure higher productivity and animal welfare
- Dynamic MultiStep – low energy consumption and optimal climate
- Dedicated software packaged for broiler, layer, and breeder that fits the specific needs
- Ensuring the right amount of feed and water to utilize growth potential completely
- Always in control - continuous calculation of FCR and EPEF



2

DOL 2300/2400 alarm

- Security for animal welfare and your investment
- Monitors temperature, humidity, empty silo, water, and fire, etc.
- Advanced temperature monitoring with outside temperature control
- Fingerprint scanner or six-digit PIN
- User-friendly touch screen with easily accessible overview menus
- DOL 2400 also monitors its power supply and battery backup



3

DOL 278 emergency opening

- ON/OFF or temperature-controlled
- In case of power failure, the first few minutes are crucial for the animal welfare
- Security for animal welfare and your investment
- Insurance companies often offer lower insurance costs due to lower risk



4

DA 1200/1211/1911/3800 wall inlet

- For build-in or wall mounted
- Uniform climate all over the house
- Inlets close tightly – no draught or false air intake
- Fully insulated – no condensation or ice formation
- Operated by a pull rod – all inlets maintain the adjusted opening degree
- Maintenance-free and long durability



5

DA 60-820 roof inlet

- For negative and equal pressure systems
- Uniform climate – also in wide houses
- Optimal for monoblock houses and questionable houses
- Not sensitive to outside wind conditions
- No draughts in the area occupied by the livestock
- Uniform distribution at 100% stepless regulation



6

17K tunnel inlet

- For Tunnel and Combi-Tunnel systems
- Uniquely suited for houses with less wall space clearance – layer cage production
 - Air direction control – optimum airflow
 - Available both with semi- and highly insulated flap
 - Airtight when closed
 - Can be used with emergency opening
 - Reduced building and fitting costs
 - Robust and easy to clean



7

DA 65-600 chill unit

- Optimum air velocity and air distribution
- High throw – fewer units to blow over long distance
- High-quality, durable materials and stands high-pressure cleaning
- Manually or power-driven elevation to facilitate the cleaning of the house
- The built-in fan has stepless control

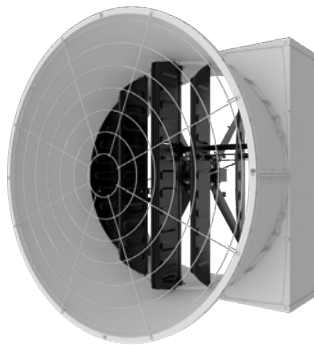

8

BF 50 BlueFan

- For Tunnel or Combi-Tunnel houses
- High performance at low energy consumption
- Non-corrosive materials – no rust or need for frequent replacements
- Pressure stable – no problem in windy areas
- Airtight shutter and well-insulated – no draught or false air intake
- Available in stepless (0-100%) variants and ON/OFF variants



9

DA 55 BlueFan

- Suitable for larger houses using Tunnel or Combi-Tunnel
- Low power consumption
- No noise when the shutter opens
- Easy to install and clean
- Higher output - fewer fans needed
- Long durability - plastic housing and plastic wings
- Plastic and stainless steel - no rust and corrosion



10

DA 600/820/920 exhaust unit

- Wide range of chimney solutions for all purposes
- Aerodynamic and optimized to the LPC fan
- Maximum air output at low energy consumption
- Robust under all weather conditions
- Profiled roofing sheets – no need for sealing
- Side or ridge-mounted – easily adapted to the roof



11

DA 2000 High-pressure cooling

- Maintain high productivity during the hot periods
- No or less drop of productivity during the hot period
- Avoid animal heat stress and higher mortality during very hot periods
- Optimize the humidity level in the house for higher productivity and animal welfare
- Dust-binding – better air quality and working environment

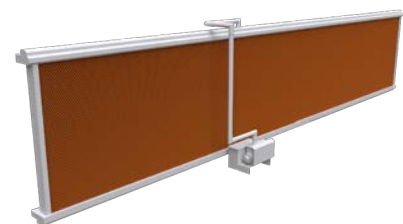

12

DA 100B/150B Pad cooling

- Maintain high productivity in the hot periods
- Big pad surface - high cooling effect results in better productivity
- No or less drop of productivity during the hot period
- Avoid animal heat stress and higher mortality during very hot periods
- No additional humidity is added to the air – can be used in areas with high humidity levels
- A robust system, even with poor water quality
- Unique solution for hot and dry areas that eliminates the temperature fluctuations

System Components



13

Spiraflex

- Finned tubes that are used for water-based room heating systems
- Spiraflex provides an optimum environment as the system does not add CO₂ to the air
- The system optimizes the air distribution at minimum ventilation – same good climate for all animals
- Spiraflex finned tubes provide efficient and cost-effective heating of the air in the house
- Fully welded finned tubes, which ensure a high, documented heat output
- Easy to install with stainless splicing sleeves, and you do not need any special tools to do it



14

DA 175 actuator

- For all kinds of air intake
- For accurate regulation of all kinds of air inlets
- LED indication for operation status
- 24V version for emergency opening
- Maintenance-free and long durability



15

DOL 114 temperature and humidity sensor

- High-precision sensor measuring relative humidity and temperature
- Two-in-one sensor
- Correct humidity measurements also in houses with changing and high humidity level
- Developed for the harsh environment in live-stock houses
- Leave it in the house during cleaning



16

DOL 119 CO₂ sensor

- Carbon dioxide measurement
- Indicator for air quality in the livestock house
- Cost-saving – optimum ventilation- and heating level
- Collect data for legislation purposes



17

DOL 53 ammonia sensor

- Measurement of ammonia (NH₃)
- Litter management control – uniform distribution
- Too high ammonia concentration results in a higher FCR, lower gain, and decreased welfare
- Corrective action according to NH₃ level



18

DOL 90 water meter

- The collected data ensures a complete overview of water consumption in the various sections or houses.
- Reliable and straightforward
- Correct water measurement

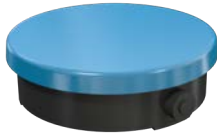

19

DOL 94 poultry scale

- Capable of weighing birds up to 10 kg. Data such as animal weight, weight distribution, number of weighings, and gain are available continuously on the production controller.
- Weighing data based on 24/7/365
- Trustworthy weighing data based on a large number of weighings
- Real-time data is always available for the management system
- DOL 94 is easy to handle, clean, and calibrate



20

DOL 98S poultry scale

- Capable of weighing birds up to 20 kg. Data such as animal weight, weight distribution, number of weighings, and gain are available continuously on the production controller.
- Weighing data based on 24/7/365
- Trustworthy weighing data based on a large number of weighings
- Real-time data is always available for the management system

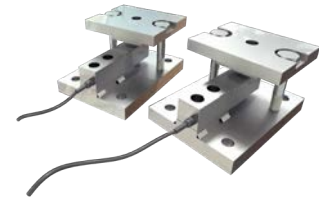

21

DOL 199 silo weighing

- A silo load cell registers the weight of the silo content and transmits it to the DOL 199 silo weighing box which transfers the data to the production controller. You can connect up to four silos to a DOL 199 silo weighing box.
- Two-in-one sensor
- Correct humidity measurements also in houses with changing and high humidity level
- Developed for the harsh environment in livestock houses
- Leave it in the house during cleaning



22

DOL 99B feed weigher

- DOL 99A weighs portions of up to 20 kg and can be connected to a production controller.
- Designed for the harsh and dusty environment in a livestock house
- Weighing of very high precision
- Simple stand-alone solution



23

DOL 9940 feed weigher

- DOL 9940 is a feed weigher that weighs portions of 10 to 40 kg. The weigher is applicable in livestock houses to ensure accurate weighing of feed consumption.
- Designed for harsh and dusty environment
- Weighing of very high precision
- The design renders feed mixing possible
- Easy access for cleaning



25

DOL 192 egg counter

- The automatic egg counter is touch-free and works using infrared light. It reduces the risk of damage and contamination and ensures an unobstructed flow of eggs on the conveyor belt.
- Range of egg counters for all conveyer belt sizes
- Egg counting based on 24/7/365
- Trustworthy data based on large numbers
- Real-time data is always available for the management system

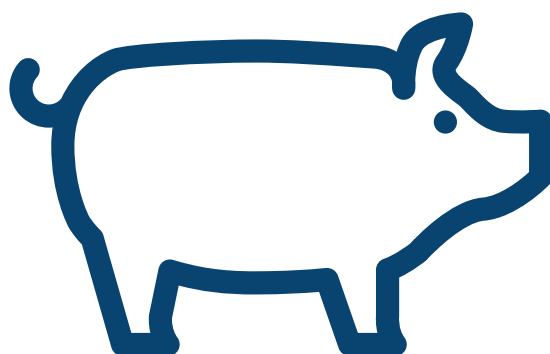
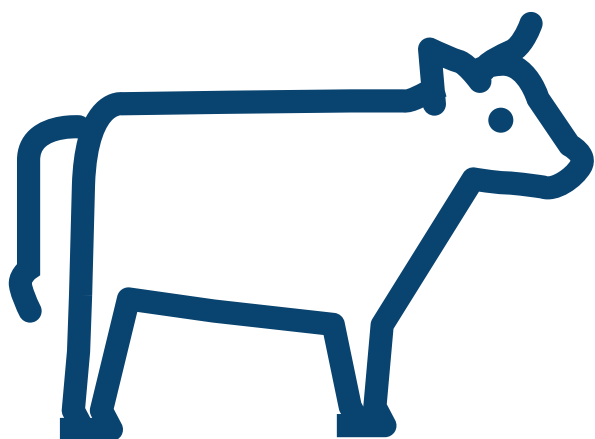

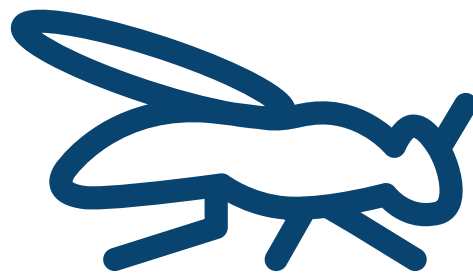

SKOV A/S

Hedelund 4 • 7870 Roslev • Denmark
T: (+45) 7217 5555

SKOV Asia Ltd.
PB Tower • 10110 Bangkok • Thailand
T: (+66) 2 382 3031-2

SKOV North America, Inc
160 Clairemont Avenue, Suite 200 • Decatur, GA 30030 • USA
T: +1 (678) 954 5743

SKOV Russia LLC
Derzhavinskaya st. 16A, office 304 • 392000 Tambov • Russia
T: +7 (4752) 49 25 39

SKOV Technical Services (Tianjin) Co., Ltd.
斯科弗技术服务(天津)有限公司
天津市武清开发区
T: 电话: (+86)-131-6178-4389

E: info@skov.com

Your service partner



LAE
ANLAGENBAU

LAE Anlagenbau GmbH
Altenwalder Chaussee 94-100
D – 27472 Cuxhaven
GERMANY
Tel.: +49 4721 105 0
FAX : +49 4721 105 210
Mail : info@lae-cuxhaven.de
Web : <https://lae-cuxhaven.de>



www.skov.com